

Nobel Biocare NEWS

Celebrating Twenty Years of Publication

Issue 1/2018



Yet Another Patient First

You can expect innovation from Nobel Biocare because Nobel Biocare delivers – time after time.

Nobel Biocare News has been reporting on advances in the field of implant-supported prosthetic solutions for twenty years now. In our very first issue, on the very first page (in what was then known as *Nobelpharma News*), we headlined how close ties between scientists and clinical researchers were essential to the success of the burgeoning enterprise that would come to be known as implant-based dentistry. This observation remains no less true today.

By Frederic Love

Kathleen Mattson's dental restoration comprises a Trefoil system solution in her mandible and an All-on-4° treatment concept solution in her maxilla. She benefits from research and development supported by Nobel Biocare in an extremely practical way.

In her own words, "I not only hope, but feel confident, that the treatment is going to have a positive impact on every aspect of my life."

Words like these have been recorded over and over again for patients benefitting from either the All-on-4° treatment concept or the Trefoil system—but never before

to conceive and shepherd unconventional solutions to market; cautious, in order to be able to substantiate every claim they make as they deliver, and then support, a new product.

"Dr. Jivraj and Dr. Zarrinkelk, who worked on my case together, found an extraordinary solution that works very well for me."

— Kathleen Mattson, pictured above

from a single patient who has received both forms of treatment at the same time.

Mattson may be the first patient to benefit from both simultaneously, but she is unlikely to be the last. Thanks in no small part to outstanding clinical results, both the All-on-4° treatment concept and the Trefoil system continue to win over new clinicians and patients every day.

You can read the story of Kathleen Mattson's treatment, in her own words, on page 3.

Not the paradox it seems

Nobel Biocare has proven itself to be a company of bold—yet scientifically reserved—professionals. Bold, in order

The results of this apparent dichotomy speak for themselves. Nobel Biocare has been first-to-market with such groundbreaking, scientifically supported innovations as the world's first successful system of dental implants—the original Brånemark System—then the first digitally designed ceramic crowns; the first zygomatic implants; the first angled abutment; the introduction of proprietary cold-worked Grade 4 Titanium; the introduction of the TiUnite surface; the launch of the All-on-4° treatment concept; the often copied, yet never equaled NobelActive implant; not to mention the recent advent of the Trefoil system; and these are just a small selec-

tion of the many unprecedented steps forward taken by Nobel Biocare over the years.

Innovation as a lifestyle

In recent years, Nobel Biocare innovative thinking has been extended to promoting basic and applied science, continuing education and humanitarian projects.

The company-sponsored Foundation for Oral Rehabilitation, FOR, for instance, has developed a pioneering online platform for dental education and treatment support. Unlike others in this T&E space, FOR provides unlimited access to content created and reviewed by leading experts in the field of dentistry, *and at no cost to the user.*

Nobel Biocare supports FOR, its ideals, and our customers with a commitment to deliver more than promised in every mutual endeavor. <

→ More to explore!

Please turn the page and read this issue's editorial by President Hans Geiselhöringer, who gives the reader a clue or two about what's coming next.

In this Issue

3 At the cutting edge
Mastering the All-on-4° treatment concept provides a practical pathway toward professional leadership



8-9 Trefoil biomechanics: "Less is more," said Mies van der Rohe. Professor John Brunski agrees. Don't miss his article: "The Three Pillars of Trefoil."

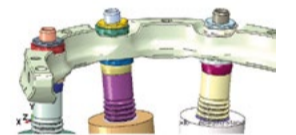

10 Prof. Tomas Albrektsson puts TiUnite to the ultimate test with colleagues from around the world.

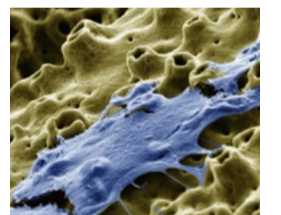

Cellular adhesion to the TiUnite surface as seen in an SEM image.

11 Save the dates now!
The next Nobel Biocare Global Symposium will be held in Las Vegas.



From the President



Hans Geiselhöringer, President

You don't establish trust overnight. Over four decades, Nobel Biocare has built the business of reliable implant dentistry by first fostering scientific discovery, then translating it into the ingenious clinical concepts that you'll find featured on these pages.

For years we've had to defend the data-based, scientific approach that has produced pioneering products, only to find our detractors copying these products in the end. But we stay a step ahead—and persevere with this approach—in order to write the next chapter of innovation.

As we launch one solution after another in the year ahead, you'll find that we retain a firm focus on enhancing esthetics and workflow efficiency while, at the same time, offering entirely new options—such as the industry's first fully metal-free two-piece ceramic implant solution.

We're working to establish new standards that will elevate the quality of products you deliver to patients. In the process, many small copycats are sure to fall by the wayside.

You have made us your partner because we are robust and reliable. We're honoured by the trust you show and are committed to supporting your day-to-day work, helping you advance your skills and business in order to serve your patients with the best possible treatment. <



Nobel Biocare NEWS

Published regularly by
Nobel Biocare Services AG

Volume 20, Number 1, 2018

Editor-in-chief Frederic Love
Managing Editor Jim Mack
Assistant Editor Chris Kendall

Editorial offices
Nobel Biocare News
Herdevägen 11
702 17 Örebro
Sweden

Telephone: +46 19-330680
e-mail: news.editors@nobelbiocare.com
web: nobelbiocare.com/news

The contents of contributors' articles do not necessarily express the opinions of Nobel Biocare.

© Nobel Biocare Services AG, 2018.
All rights reserved.

Working at the Cutting Edge

The new and improved All-on-4® treatment concept is poised to help you further differentiate.

Progressive clinicians demand progressive solutions. That's why clinicians looking to improve treatment outcomes and grow their practice are using the All-on-4® treatment concept. Today backed by almost 20 years of clinical success, this established and proven approach for restoring full arches continues to evolve. Thanks to Nobel Biocare's latest innovations, the All-on-4® treatment concept is more life-changing than ever, both for patients and dental professionals.

By Núria Serra

The key principle of the All-on-4® treatment concept is well known—it makes the full, graftless rehabilitation of an edentulous mandibular or maxillary arch possible with just four implants and allows a provisional restoration to be placed on the day of surgery.*

With the latest innovations from Nobel Biocare, the next generation of this well-documented treatment protocol has arrived. New versions of implants and abutments plus versatile restorative options mean that even more patients and practices can benefit from the proven benefits of the All-on-4® treatment concept.

The right implant

Today, Nobel Biocare offers more implant options than ever before for the All-on-4® treatment concept, providing clinicians with the right implant for every case.

The NobelSpeedy implant system, the original and widely documented option for the All-on-4® treatment concept, is available in more lengths and diameters for increased surgical flexibility. Shorter, longer and wider versions have been added to an expanded NobelSpeedy Groovy range. All are designed to further help clinicians utilize a graftless approach and achieve cortical anchorage, even where bone quality and quantity are limited. These new options will allow even more patients to benefit from the proven advantages of the All-on-4® treatment concept.

In cases where maxillary bone is severely resorbed, the placement of zygomatic implants can nonetheless make graftless restoration of the full arch on four implants possible. Build-

ing on 25 years of success with Nobel Biocare's zygomatic implants, the newest Nobel-Zygoma 0° and 45° implants provide greater surgical and prosthetic flexibility than previous options. They have an unthreaded implant body designed to interface with soft tissue and, depending on the anatomical situation, parts of the implant body can be located outside of the maxillary sinus. A new tapered apex design has been designed to support high primary stability for Immediate Function.

All these options are intended to make it possible for clinicians to utilize the proven benefits of the All-on-4® treatment concept in more cases, helping them build a reputation for rapidly restoring quality of life for patients who are experiencing the problems associated with dentures or a failing dentition.

Reduce restorative chair time

In order for a clinician to be able to offer the benefits of the All-on-4® treatment concept to more patients, treatment efficiency is also a key consideration. If patients spend less time in the chair, they will be more comfortable during treatment, and clinicians will consequently have the chance to successfully treat more patients in a day.

With this in mind, Nobel Biocare has introduced the Multi-unit Abutment Plus. The successor to the company's original, and extremely popular, Multi-unit Abutment, this updated version is designed to significantly reduce the chair time required to perform provisionalization processes such as a denture conversion—a procedure commonly used in the All-on-4® treatment concept.

By introducing a snap-fit function between the temporary cylinders and the abutment, screws are no longer required during the try-in process. This means the common practice of removing the temporary cylinders and the denture several times during the conversion process can be done in a few snaps—with no need to tighten and loosen four screws each time—saving valuable time for the clinician and lab technician.

For further ease, speed and efficiency in choosing the correct Multi-unit Abutment rotational position and angulation, the Multi-unit Aligning Instrument is now available for conical connection and Tri-Lobe. This latest innovation makes it easy to identify the angulation of the most-

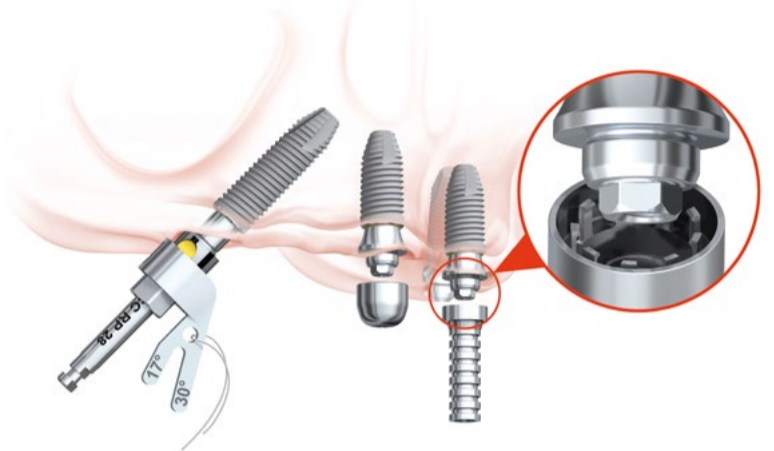

The new Multi-unit Alignment Instrument makes it easy to identify the angulation of the most-suitable Multi-unit Abutment and the rotational position of the implant; and the broad assortment of Titanium Multi-unit Healing Caps makes individualized treatment possible.

suitable Multi-unit Abutment and the rotational position of the implant, helping to optimize the final abutment position and prosthetic design.

In addition, the Titanium Multi-unit Healing Cap assortment (see above) facilitates the placement of the provisional prosthesis. Designed to help individualize treatment, this newly expanded portfolio of healing caps provides clinicians with a choice of dimensions and designs to suit the thickness of the soft tissue. These one-piece components are made of titanium to provide ease of placement, and are single-use to prevent the deformity that can be caused by repeated sterilization.

When it comes to the final restoration, NobelProcera offers a wide variety of precision-milled CAD/CAM restorations offering easy handling, long-term predictability and a precise fit.

The All-on-4® treatment concept – the key to practice progression?

For a dental office to be at the forefront of the profession, it has to stand out from the competition. If the practice team wants to build a strong reputation, they need to offer effective treatment that leaves patients satisfied to the extent that they are willing to share their positive experiences with others. In this regard, few treatment options come close to the proven success of the All-on-4® treatment concept.

According to research, 95% of All-on-4® treatment concept patients were satisfied with their new teeth, and fully 88% said they would definitely recommend similar treatment to friends and colleagues.

There's no reason this positive patient response won't last, with long-term success documented for All-on-4® in both the edentulous maxilla

and mandible. Long-term follow-up shows high cumulative survival rates of 94.8% in the mandible after ten years and 98.0% in the maxilla after five years.

Becoming known for such success can help significantly increase patient flow. In fact, 24% of those that attended a Nobel Biocare All-on-4® treatment concept course grew the number of implants they placed by 50% the following year.

Importantly, this new generation of componentry is just the next step in the continuous evolution of the All-on-4® treatment concept. As the company behind the original concept, Nobel Biocare is committed to further enhancing the componentry and workflow for All-on-4®.

Thanks to this commitment, clinicians who take advantage of the treatment concept's proven benefits will find themselves firmly at the forefront of their profession not just today, but for the foreseeable future.

Want to become part of the All-on-4® treatment concept success story? Go to nobelbiocare.com/all-on-4 to download an e-book that will get you started by introducing the concept's key principles. You can also sign up there for a new premier online training course presented by leading All-on-4® treatment concept experts. <

* For patients meeting criteria for the immediate loading of implants.

→ More to explore!

Contact your local Nobel Biocare representative to find out how you and your patients can be part of the All-on-4® treatment concept success story. More information can be found at: nobelbiocare.com/all-on-4.

For the complete list of references for this article, please visit: nobelbiocare.com/news

Science matters

Factors affecting implant fracture

Factors influencing the fracture of dental implants. (Chrcanovic et al., Clin Implant Dent Relat Res. 2017)

Although rare, the fracture risk for dental implants is an important consideration. Implant fracture can be problematic, resulting in the loss of the implant and possibly the prosthesis.

Chrcanovic and coworkers examined the prevalence of implant fractures and risk factors leading to fracture in 2670 patients. They observed fractures in 0.44% of placed implants. Higher grades of titanium and increased implant diameter decreased the risk of fracture, while increased implant length, adjacency to cantilever, and bruxism increased the risk. Overall, Nobel Biocare NobelActive implants showed significantly lower fracture rates (0%) than Straumann SLA® (2.11%) and Astra OsseoSpeed™ (1.43%) implants. Differences were reported to be especially evident in narrow-diameter implants: NobelActive implants had no fractures whereas Astra OsseoSpeed implants had a moderate fracture rate (2.10%). The authors found Straumann SLA implants “presented by far the highest fracture rate” (7.31%) of the implants studied in this publication.

→ ncbi.nlm.nih.gov/pubmed/29210188

Precision design facilitates success

10 years' clinical success with NobelProcera on TiUnite implants placed using computer-guided surgery. (Tallarico and Meloni, Int J Oral Maxillofac Implants. 2017)

Published trials evaluating long-term rates of survival and biological complications following computer-guided implant rehabilitation are rare.

This retrospective case series study assessed the long-term clinical success of implants planned with NobelClinician and inserted using NobelGuide (fully guided or pilot) in private practices. In total, 141 fully or partially edentulous patients received 694 TiUnite-surface implants between 2006 and 2015. All patients received NobelProcera CAD/CAM restorations.

Patients were followed for 1–10 years (mean of 4.8 years). Implant survival was 97.4% at 10 years. The prevalence of peri-implantitis was 2.8% (4 patients). Two cases of peri-implantitis were judged to be surgically triggered and two were diagnosed in patients with concomitant depressive disorders.

Authors attributed the high survival and low complication rates to adequate passive fit and a decreased risk of cement-related peri-implantitis due to customization of the cement line with NobelProcera.

→ ncbi.nlm.nih.gov/pubmed/28906510

Modelling osseointegration better

Biophysical regulation of osteotomy healing: An animal study. (Wang et al., Clin Implant Dent Relat Res. 2017)

Many factors influence osseointegration, such as bone type and quality of bone-to-implant contact. However, the concept of “ideal” site preparation is poorly defined.

Wang and coworkers used a mouse model to investigate the effects of heat generation during osteotomy on bone remodeling around implants. They used drill diameters and radial velocities that were designed to be representative of site preparation in the clinic.

During osteotomy, faster drill speeds led to increased heat generation versus slower speeds. Consequently, osteocyte death in the surrounding bone was more prevalent after faster versus slower drilling. Also, after three days, less new bone formed in sites where faster versus slower drill speeds had been used. These results help to better define the cellular repercussions of drilling, and show how carefully designed, clinically representative animal models may be useful to inform future practice.

→ ncbi.nlm.nih.gov/pubmed/28608504

“A positive impact on every aspect of my life”

The Trefoil system and the All-on-4® treatment concept in one case

Kathleen Mattson suffers from the early-onset of Parkinson's disease, which over time, and in combination with her medication, had caused her natural teeth to deteriorate significantly. Anxious to find a solution, Kathleen approached Dr. Saj Jivraj, in California. Dr. Jivraj and oral surgeon Dr. Hooman Zarrinkelk suggested the Trefoil system to restore the mandible and the All-on-4® treatment concept to restore the maxilla. Accepting their advice, Kathleen was able to benefit from fixed prostheses from the day of surgery. Here, she tells her story.

By Kathleen Mattson

Parkinson's disease, and side effects of the medication that I was taking for it, gave me a really dry mouth. There didn't seem to be anything that could provide enough moisture for me to feel good, nor even to help me escape the damage that the unrelenting dryness was doing to my teeth.

Because I just didn't know where to turn, I allowed these difficulties to continue for about five years. Then I found Anacapa Art Dental online, and I made an appointment.

Going in, the prospect of a surgical procedure terrified me. I thought there would be no way I could go under a general anesthesia. And I worried it was simply not going to work—that with my Parkinson's the procedure would just be too much.

But then I met Dr. Jivraj and his office manager, Josee, who took my qualms seriously, and were very kind to me as they addressed my misgivings. After this visit, I felt reassured.

Josee told me, “Anything is possible!” with such conviction that these three words encouraged me throughout the process ahead.

From words to action

The full-mouth restoration went really well for me, and I healed quickly. I am very happy with my new teeth.

For 30 years, I was a physical therapy assistant, so I know the medical field and can attest that the standard of care I received was excellent. Everything went very quickly for me, with no complications.



Confidence regained, Kathleen Mattson has plans for the future: “I'm considering some voice-over work, getting back to stage plays, and directing.”

Following the surgery, I took some stronger pain pills for the first few days, and then it was just ibuprofen. Within a week I didn't need any pain medication at all. I did have to have a soft diet for a short time, but that really wasn't so bad. In short, any fears that I may have had before the treatment were totally unfounded in my experience.

Like my own teeth

As the swelling subsided, I realized how comfortable I was with the prosthetics—and am still—because they work so well. They actually feel quite like my own teeth.

Now, my teeth have matching surfaces that help me to chew better. I'm also feeling confident about the future, since the implants should help to forestall bone resorption—so my face shape shouldn't change as it might have had I chosen dentures.

I don't believe I could wear dentures in any case because my mouth likely wouldn't hold them—the

plates would slide. Dr. Jivraj and Dr. Zarrinkelk, who worked on my case together, found an extraordinary solution that works very well for me. I have a lot to thank them for.

So what is ahead for me now? Before I was diagnosed with Parkinson's, acting and directing was a passion of mine. Now, with the restored confidence my new teeth have given me, I'm considering doing some voice-over work, getting back to stage plays, and directing. Today I not only hope, but feel confident, that the treatment is going to have a positive impact on every aspect of my life. <

→ **More to explore!**

To see how the Trefoil system and the All-on-4® treatment concept can revolutionize your practice and the lives of many of your patients, please visit:

nobelbiocare.com/all-on-4 and nobelbiocare.com/trefoil.

Moving Forward

New Executive Director at FOR



Science, education and better patient treatment are fundamental goals of FOR. The newly appointed Executive Director, Dr. Michael Hotze, brings exemplary expertise to the foundation. With a background in clinical research, he specializes in the crucial mission of communicating science in an accessible, digestible and educational way.

• **Tell us about your background, and your new role at FOR.**

I did my PhD in Biochemistry, before entering the field of dentistry in 1999 at the research department of Colgate-Palmolive. I joined Straumann in 2004 as their Head of Clinical Research, and I managed their collaboration with an educational institution. Today, I am delighted to become Nobel Biocare's first Director of Clinical Communications, which includes the executive director responsibilities at FOR. I am working closely with the FOR Board of Directors to drive a wealth of knowledge and education.

• **When did you first discover FOR?**

I registered with FOR back in 2013. From the beginning, it was strongly endorsed by many opinion leaders, and I was captivated by the substantial amount of high-quality resources.



• **What are your future aims for FOR?**

We already have a substantial volume of content and a fast-growing community of over 27,000 users, which provides a very strong starting point for three main plans. The first is to develop even more online offerings, such as our eBooks, ePapers, and treatment guidelines. Secondly, I want to build on face-to-face networking opportunities for our users, especially in regions around the world where dental implantology is still in early development. Thirdly, I want us to give support to and collaborate with the next generation of experts in order to reflect the significant changes we're seeing in dentistry professional demographics.

• **What do you find most inspiring about FOR?**

Having over 27,000 users makes FOR one of the biggest providers of educational content in dentistry. With our global reach, FOR is an important platform to publish and share experience within the scientific community, helping young and ambitious clinicians to grow and develop their careers. Many scientific associations hold classic conference and symposia events, which are highly valuable, but often difficult at a practical level for professionals to attend. Digital learning platforms will definitely play a stronger role for education in the future, making the digital pathways provided by FOR an invaluable way to disseminate knowledge and education.

What's more, FOR's activities also cover the humanitarian aspects of dentistry, promoting patient care in underserved populations, which makes it really unique. In that same vein, FOR has made all content accessible free of charge, in order to encourage engagement by providing resources and education for users across the globe.

• **What do you look forward to most in working with FOR?**

When I started back in November, I found a highly motivated team and an inspiring environment. The ongoing projects were all well on track and I could concentrate on the next steps, new projects and strategic plans for the future of FOR.

→ for.org/en/user/sign-up

Five Things You Need to Know about NobelProcera® Services

Leading lab technicians around the world avoid much of the expense associated with production equipment, maintenance and stock by working with NobelProcera Services instead. Best of all, getting started has never been easier.

By Arjun Sarof

For busy technicians, NobelProcera Services now offers more support options than ever before. Here are the five facts you need to know about NobelProcera's ever-expanding range of outsourcing opportunities for the scan, design and production of precision-engineered CAD/CAM restorations.

1) No equipment costs

Investing in new in-lab milling equipment is one option for expanding a lab's offering. For some lab owners however, the initial investment can be off-putting or even prohibitive. Maintenance costs also need to be taken into account and there's the practical consideration of finding space in the laboratory for new equipment.

Outsourcing with NobelProcera Services means you can offer an expanded product range without initial investments. There's not even a need to purchase a scanner or software, as models can be sent directly to NobelProcera's skilled technicians for scanning and design.* Alternatively, technicians can provide scan data or a full design for industrial production—the choice is theirs.

The flexibility of the service is something that many technicians may find appealing. NobelProcera Services can be utilized whenever the case requires it, with no risk of expensive equipment being underutilized.

2) Only precision-engineered components

NobelProcera's centralized production facilities use advanced industrial milling technology to provide technicians with quality restorations that are designed for a precise fit. NobelProcera abutments and bars meet the required regulatory requirements, e.g., FDA clearance, CE marking etc., while all NobelProcera restorations are backed by a five-year warranty to give technicians and their customers peace of mind.

In addition, Nobel Biocare implants restored with a NobelProcera restoration are covered by a lifetime warranty. It's important to note that restorations from over 170 other implant platforms are also available via NobelProcera Services.

NobelProcera's range of innovative restorations for Nobel Biocare implants offer ease-of-use enhancing features such as the angulated screw channel (ASC) option. The NobelProcera ASC solution allows the repositioning of the screw access hole in cases where it would otherwise be on the facial or incisal edge, or when occlusal space is limited. At the same time, the cement-free ASC option can also improve retrievability.

3) Wide selection of scanners supported

There's a greater chance than ever before that a dental professional's scanner of choice is supported by NobelProcera Services. The ambition is for as many scanners as possible to link with the service, provided they meet the high standards required for implant dentistry. Well-known brands such as 3Shape® and iTero® are among the manufacturers of the 25 desktop and intraoral scanners compatible for submitting

cases to NobelProcera production, and the list of supported scanners continues to grow.

4) Intraoral scanner workflow with online ordering now available

As intraoral scanner technology continues to improve, uptake among clinical teams is likely to increase. Dental professionals that prefer to take digital impressions using intraoral scanning technology can now be catered for easily using a fully digital NobelProcera Services workflow for abutments. Technicians can submit the case to the NobelProcera team easily using an online order form and uploading 3Shape or NobelProcera scan files. No additional software is required.

5) Co-packing for added convenience

CAD/CAM implant bars, abutments and crowns have been available through NobelProcera Services for some time, but the scope of services offered has now expanded. Newly added is a co-packing option that provides a simple restorative workflow for intraoral scan cases.

This allows the technician to receive the NobelProcera Abutment or Crown co-packed together with a 3D-printed model from approved vendor, Dreve. It's a helpful option when working with digital impressions, where a traditional model is not produced as a matter of course. <

* Some products may not be regulatory cleared/released for sale in all markets.

→ More to explore!

To learn more about the full range of NobelProcera Services, visit:

nobelbiocare.com/
nobelproceraservices.com/



Looking for easy access to NobelProcera Abutments and Implant Bars? By outsourcing to NobelProcera Services you gain more time to focus on the work that provides the greatest return for your lab. What's more, when using NobelProcera prosthetic components, you benefit from the peace of mind provided by a lifetime warranty for your Nobel Biocare implants, and a comprehensive five-year warranty for your NobelProcera restorations.

Digital Integration From Beginning to End

Breaking down boundaries between clinician and technician

Nobel Biocare recently introduced an expanded CAD/CAM offering, designed to enhance flexibility and connectivity between treatment partners. This new offering is made possible through the company's close partnership with KaVo.

Nobel Biocare is expanding its CAD/CAM offering with new flexibility and connectivity. New KaVo imaging equipment and DTX Studio software are part and parcel of the two companies' collaborative efforts.

Bringing complementary areas of expertise to the partnership, these two leading dental innovators are now developing fully integrated digital equipment and software solutions designed to bring about seamless, beginning-to-end treatment workflows for clinics and laboratories.

New imaging device

The KaVo LS 3 desktop scanner starts the digital journey for the clinician and lab technician with speed, color and precision. Designed to enhance efficiency, it seamlessly connects to DTX

Studio design for fast restoration planning. Dental technicians can save time without compromising quality—a complete jaw scan can be performed in under 60 seconds with an accuracy, according to ISO 12836, of up to 4 µm—even when working on the most complex cases.

The KaVo LS 3 desktop scanner is equipped with an advanced optical system that captures the fine textures and colors of the dental model for true visualization; and scans can be managed directly at the scanner itself, using its intuitive 5-inch touchscreen interface. Designed with an awareness of the virtue of mechanical simplicity, its spacious, open design provides easy access to the case, and makes it possible to mount a full articulator, thus further increasing efficiency at the dental laboratory.

Connectivity for everyone

The DTX Studio suite offers exciting



Nobel Biocare's expanded CAD/CAM offering includes a new KaVo imaging device fully integrated with DTX Studio software.

new solutions in connecting the modern dental professional with the entire treatment team at each stage of dental implant treatment. It integrates the very latest technologies and equipment from patient imaging acquisition to post-treatment follow-up—including diagnostics, treatment planning, guiding implant surgery and restoration design.

It is now possible to manage 2D and 3D data from X-ray and optical sources in a single software application throughout the practice.

DTX Studio for clinics processes data in dentistry-relevant workspaces and is geared towards daily use in both Windows® and macOS® environments. It provides users

tained restorations in-house. Using the new KaVo LS 3 scanner in combination with the DTX Studio design software, dental technicians will be able to access the full portfolio of NobelProcera restorations.

With the resulting smooth, fast workflows, they can choose to produce authentic, precision-engineered NobelProcera CAD/CAM solutions outsourced to high-tech facilities in Mahwah, New Jersey, USA, and Chiba, Japan.

Manufactured in accordance with the ISO 13485 quality management system and cleared by the FDA where required, the output quality of every prosthetic is monitored. This results in products demonstrating a

high degree of precision fit. When assistance is needed, direct local support is available from Nobel Biocare specialists who

are fully trained on the workflow.

Digital production on demand

NobelProcera Scan and Design Services (see related article on page 4) help laboratories consistently meet increasing demands for high-quality implant-based restorations without calling for substantial investments in new equipment and staff training.

One can send a case from any one of 25 different approved scanners to NobelProcera Scan and Design Services, and then receive precision-fit bars, abutments and implant crowns, and/or a 3D printed model.

Whether using an IOS or desktop scanner, the process is simple—and within a matter of days, the precisely manufactured restoration is shipped to the lab with a material authenticity certificate and a five-year product warranty. <

with tools for ease and efficiency, such as online collaboration between DTX Studio implant and DTX Studio design for laboratories—whereby a TempShell provisional can be produced in-house for same-day, immediate screw-retained provisionals.

For dental laboratories, the DTX Studio suite brings a new opportunity to become the 'go-to' lab of the future, facilitating flexibility in the choice of workflow and business model.

DTX Studio design software will accept intraoral scan files from systems such as TRIOS®, iTero®, 3M™ and Carestream Dental™, as well as files from other desktop scanners. Furthermore, lab owners will benefit from the best of two worlds: 'Direct access' to premium NobelProcera centrally manufactured products including bars, and 'open output' with the option to produce cement-re-

"The LS 3 delivers precision with increased speed and efficiency—great for my team and even better for the patient!"

— Professor Paulo Malo

In Brief

Get ready for change!

The 2019 Nobel Biocare Global Symposium will be held at the Mandalay Bay in Las Vegas, Nevada, USA from June 27–29, 2019. Save the dates now and sign up for updates today!

Change is coming. If you can only get to one symposium in 2019, Nobel Biocare's premiere event should be it. Knowledge changes everything, and true science, original solutions and profound innovation are part and parcel of this symposium.

Join Nobel Biocare for three future-focused days in Las Vegas, featuring expert speakers, master classes, hands-on training, innovative new solutions and the chance to connect with the best minds in a wide variety of specialties from around the world. Dr. Peter Wöhrle is chairing the scientific committee that is composing a program to enlighten and train an expected 3,500 participants.

In order to secure your seat at the symposium, go to the following website, see the introductory video, and then sign up for the updates that will make you one of the first to know when registration opens up later this year:

→ nobelbiocare.com/global-symposium-2019



Sverker Prize winners

At Swedental, the largest annual dental convention in Scandinavia, Drs. Matts Andersson and Agneta Odén were presented with the Sverker Prize by the Gothenburg Dental Association and the American Dental Society of Sweden.

They were awarded this celebrated prize—named for the late Swedish dentist and humanitarian, Sverker Toreskog—in connection with a lecture in digital prosthetics held at the convention. This year the Sverker Prize was presented in recognition of these two scientists' efforts "to develop and change the way we work with and manufacture ceramic materials for dental care."

Professor Matts Andersson invented the digital Procera method for the industrial production of dental crowns in the early 1980s. In cooperation with the material researcher, Agneta Odén, he developed a process for the production of dental prosthetics with passive fit and high esthetics. Nobel Biocare subsequently introduced the first commercially available ceramic CAD/CAM dental crown in 1989.

→ goo.gl/5CR2MA

Two-piece ceramic solution

At the 2017 European Association of Osseointegration (EAO) Congress in Madrid, Spain, Nobel Biocare announced it has entered into a partnership agreement with Dentalpoint AG, an international leader in ceramic dental implants. As a result, Nobel Biocare will be adding a zirconia implant solution to its portfolio.

The partnership with Dentalpoint AG will add a new implant alternative to Nobel Biocare's leading range of titanium dental implants with the clinically proven TiUnite surface. The innovations from Dentalpoint AG are intended to help clinicians meet patient demand for metal-free solutions and high-end esthetics.

As a result of the partnership, an all-ceramic solution featuring first-of-a-kind technology by DentalPoint will be available from Nobel Biocare.* The introduction of a ceramic implant will further extend Nobel Biocare's comprehensive offering of innovative solutions for excellent esthetics.

→ * For CE markets only. Under FDA 510k Review.

Over a Decade of Dominance

Often copied, never equaled – NobelActive celebrates 10+ years of clinical experience with an abundance of evidence.

The advent of NobelActive represented a major breakthrough in implant design. Today, over a decade later, a wealth of evidence proves it to be a triumph of applied biotechnology.

By Chris Kendall

It is the leading, most prominent implant solution in Nobel Biocare's extensive and diverse range of implants. Its name: NobelActive.

To date, 42 clinical studies have evaluated over 14,300 NobelActive implants involving over 2,600 patients—and this count only includes studies that examined a minimum of ten NobelActive implants followed-up for more than one-year.

Count on good primary stability

The infographic on this spread highlights just a few of the many studies that have shown NobelActive can accomplish good primary stability in demanding situations.

The reverse-cutting flutes with drilling blades on the apex enable the adjustment of the implant position during placement for an optimized restorative orientation, particularly in extraction sites.

Furthermore, internal conical connection with hexagonal interlocking offers high mechanical strength. Given such applicability, NobelActive's mean implant survival rate of 98.5%—in studies with up to, and including, 5 years of follow-up—is all the more impressive.

Count on excellent esthetics

Studies show that NobelActive preserves the critical marginal bone and soft tissue over time for natural-looking esthetics. Its back-tapered collar—together with a strong conical connection and built-in platform shifting—can aid crestal bone and soft-tissue preservation.

In the end, of course, it's all about the final results; and in terms of esthetics, self-esteem, speech, sense and function, patients treated with NobelActive implants have given high marks to its use from pre-treatment, to prosthetic delivery, all the way through three-year follow-up. <

The One and Only NobelActive

Imitation may be the sincerest form of flattery, but proof of performance only comes with a huge body of scientific evidence.

2008

PRIMARY STABILITY – RIGHT FROM THE START

Launched over 10 years ago, this unique implant design enables good primary stability, even in soft bone and fresh extraction sockets – already shown in multiple publications in 2009.

(Irinakis et al., 2009(1); Irinakis et al., 2009(2); Kielbassa et al., 2009)

2009

2010

2011

2012

2013

EXCELLENT TREATMENT OUTCOMES USING ALL-ON-4

NobelActive is demonstrated to enable efficient and reliable full-arch restorations with the All-on-4® treatment concept.

(Babbush et al., 2012)

AN IMPLANT FOR EVERY NEED

3.0 NP 3.5 RP 4.3 RP 5.0 WP 5.5

MARGINAL BONE RESPONSE

NobelActive is proven to preserve the critical marginal bone and soft tissue over time for natural-looking esthetics.

(Gultekin et al., 2013; Pozzi et al., 2014; Kolinski et al., 2014; Cosyn et al., 2016)

Patented back-tapered collar provides the space for additional marginal bone.



FIND OUT MORE

Discover even more about this groundbreaking solution:
nobelbiocare.com/nobelactive

ABUNDANCE OF RESEARCH THAT MATTERS

In peer-reviewed publications, with a minimum of 10 NobelActive implants and minimum of 1-year follow-up time.

42
clinical studies

98.5%
mean survival*

*Up to 5 years of follow-up

Over
14,300
implants
clinically studied

Over
2,600
patients
evaluated

2018

100% SURVIVAL

At a mean of 6 years (range 4.7 years up to 6.7 years), with 24 patients in a 6-year retrospective analysis.

(Polizzi et al., 2017)

SAFE IMPLANT PLACEMENT IN AREAS WITH LIMITED SPACE

Published in 2018, this new study confirms that NobelActive 3.0 is a reliable solution for narrow interdental space situations.

(Kolinski et al., 2018)

2017

IMPLANT DESIGN IS IMPORTANT FOR ACHIEVING PRIMARY STABILITY

In a study that used a polyurethane foam sandwich model, the mean implant insertion torque of NobelActive implants was 36.52 Ncm – significantly higher than both Straumann Bone Level Tapered (BLT) and Dentsply OsseoSpeed EV (Astra).

(Karl & Irastorza Landa., 2017)

2016

STUDY SHOWS REMARKABLE BONE PRESERVATION

Up to 5 years from a baseline of implant insertion.

(Cosyn et al., 2016)

2015

EXCELLENT CLINICAL OUTCOMES

A study with immediately loaded NobelActive implants placed flaplessly with NobelGuide finds high patient satisfaction, a high survival rate, stable bone levels and a predictable treatment method.

(Yamada et al., 2015)

2014

PAPILLA SIZE IMPROVES SIGNIFICANTLY

An extraction-site study using NobelActive implants with immediate loading protocol shows significant overall increase in papilla score from implant placement to the 3-year follow-up.

(Kolinski et al., 2014)

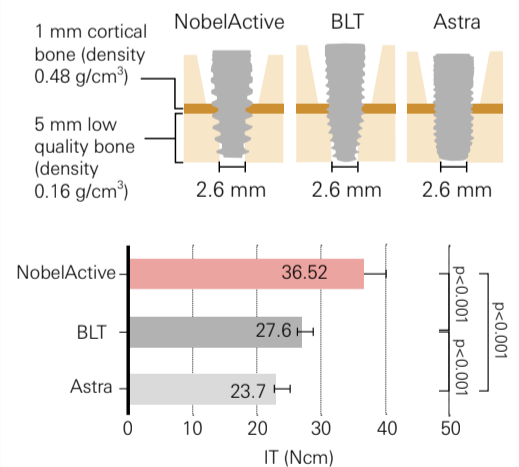

(Karl M, Irastorza-Landa A. Does implant design affect primary stability in extraction sites? Quintessence Int. 2017;48(3):219-224)

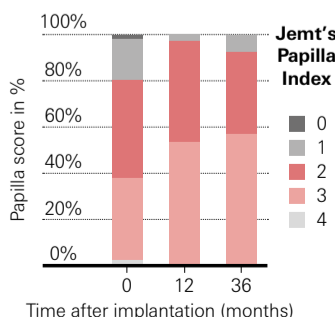

JEMT'S PAPILLA INDEX*

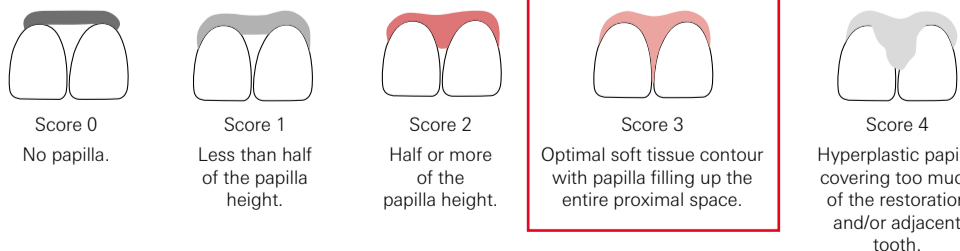

* Jemt T. Regeneration of gingival papillae after single-implant treatment. Int J Periodont Rest Dent 1997;17:327-33

→ More to explore!

For the complete list of references for this article, please visit:

nobelbiocare.com/news

The Three Pillars of Trefoil™

Trefoil has been designed and developed to extend the benefits of osseointegration to a new patient population.

In the most recent issue of *Nobel Biocare News*, the editors introduced our readers to Trefoil. In the article below, you are invited to dive deeply into the innovative bioengineering that has made this solution possible.

By Professor John B. Brunski

Even to the casual observer, it's obvious that Trefoil has a particularly innovative feature. Its prefabricated framework contains a special adaptive fixation mechanism at each implant connection that functions to create a precision fit by compensating for any slight angular ($\pm 4^\circ$), horizontal (± 0.4 mm), and/or vertical (± 0.5 mm) misalignment of the implants. (Figures 1A and 1B.)

As exciting as this feature is, there is so much more to the design of Trefoil. A great deal of biomechanical engineering insight has been incorporated into its design and subsequent clinical application.

Consider the words of Steve Jobs: "Design is a funny word. Some people think design means 'how it looks.' But of course, if you dig deeper, it's really 'how it works.'"

In this article, I hope to explain Trefoil's biomechanical design in the spirit of this quote. With a nod of appreciation to the late Philip Kapleau and his book, *The Three Pillars of Zen*, I'd like to introduce you to the "Three Pillars of Trefoil."

Pillar 1: Teachings

Individualized fit can be provided with a standardized device.

Small deviations in implant placement can greatly influence the strain distribution on the implants, the framework and surrounding anatomy. Ideally, a prosthetic framework should not introduce strain on the supporting implants and surrounding bone in the absence of an external load. This is known as passive fit.

Many studies throughout the scientific literature reveal that, in the past, cast bars and some premanufactured prosthetics experienced unfavorable levels of implant and prosthetic failures. While many factors can contribute to failures, mechanical complications such as implant and prosthetic fractures and screw loosening have been attribut-



Fig. 1A

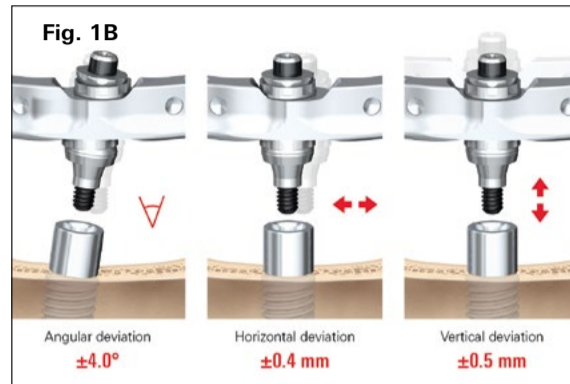

Fig. 1B

Figures 1A and B: Here is the first pre-manufactured bar with passive fit. Anatomically designed for the natural arch of the lower jaw, the standardized Trefoil system bar contains adaptive joints that adjust to compensate for horizontal, vertical and angular deviations from the ideal implant position.

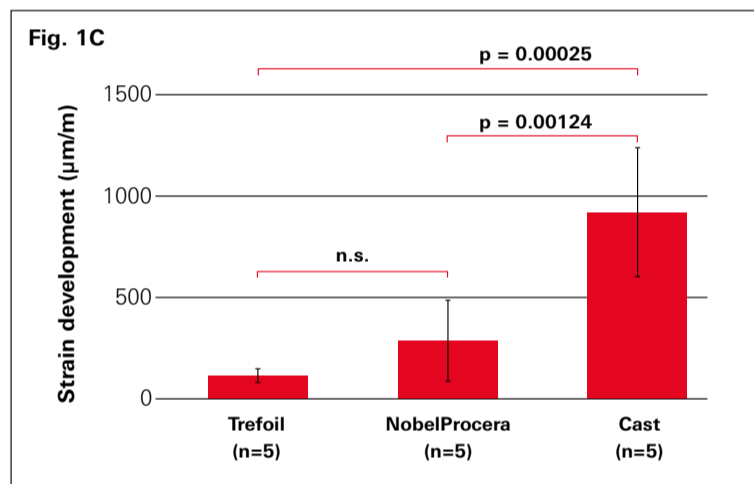

Figure 1C: A recent in vitro study conducted at Saarland University in which the Trefoil Bar was directly compared to both traditional cast bars and CAD/CAM individualized bars, cast bars show significantly higher levels of misfit and more uneven distributions of strain compared to other comparison groups. (See "More to explore" for the source reference.)

"Design is a funny word. Some people think design means 'how it looks.' But of course, if you dig deeper, it's really about 'how it works.'"

— Steve Jobs

ed to excess mechanical strain due to a lack of passive fit.

Historically, there have been many approaches to achieve passive fit. This has included cutting prosthetic bars and piecing them back together intraorally. From an engineering perspective, one might worry that this approach could affect the integrity of the prosthetic superstructure. Alternatively, the development of CAD/CAM individualized solutions has made great strides to address the issue of passive fit. However, individualized bars are still subject to deviations in implant placement and they can be expensive for many patients due to the need for multiple clinical visits and the use of a provisional prosthesis while the definitive solution is manufactured.

By contrast, with the Trefoil system, a dental team can deliver—on the day of surgery—a definitive solution that fits like a custom solution.

This is evidenced by a recent *in vitro* study conducted at Saarland University in which the Trefoil Bar was directly compared to both traditional cast bars and CAD/CAM customized bars. In this study, five replicates of each comparison framework were seated on three NobelParallel CC Tissue Collar RP 5.0 x 13 mm implants placed in resin models representing edentulous jaws using the Trefoil surgical guides and templates. Strain gauges were mounted to each system and recorded the strain development at all three implant sites when the clinical screws were tightened to 35 Ncm.

The results indicated that cast bars show significantly higher levels of misfit and more uneven distributions of strain compared to other comparison groups (Figure 1C). The Trefoil and CAD/CAM bars each had a low level of misfit and more even distribution of strain. The two systems were not statistically different from each other.

The articulating disks of the Trefoil system tackle the issue of misfit at the implant-framework interface while maintaining the integrity of the individual components. While no system showed a strain measurement of 0 µm/m, Trefoil's innovative compensation mechanism enabled a premanufactured bar to fit as well as a state-of-the-art individualized restoration.

Pillar 2: Practice

A cantilever's dimensions and loading govern how it's stressed.

An in-depth stress analysis of Trefoil needs to go beyond the above. A relevant quote from the architect Mies van der Rohe speaks to a key issue: "No design is possible until the materials with which you design are completely understood."

Indeed, from a bioengineering perspective, the mechanical success vs. failure of any oral implant system depends not only on how many implants are used and how they are loaded, but also on the sizes of the implants, the bone anchorage area, and the size and rigidity of the framework.

In other words, "size matters" because the ultimate failure limits of materials—such as the ultimate tensile strength and the fatigue strength of commercially pure titanium (CP Ti), Ti-6Al-4V alloy, and bone—are expressed in terms of stress, not force, and stress depends on dimen-

sions. So in this spirit, let's explore more details of a stress analysis of Trefoil, with a focus on framework design.

A common clinical evaluation of a framework's design involves measuring the "AP (anterior-posterior) spread", which is the distance from a line drawn between the posterior aspects of the two most distal abutment interfaces and the midpoint of the most anterior abutment/implant in the arch. Depending on whom you read, the recommended maximum cantilever length of a framework almost always falls between 1.5 and 2.5 times the AP implant spread.

Trefoil's AP implant spread is 8.7 mm, while the AP bar spread is 14.5 mm. This a ratio of 1.67, which—according to this widely accepted "AP spread rule"—is well below the maximum recommended range for this configuration.

But a calculation based on the AP spread is not a stress analysis; it's only a guideline, with its predictive value depending upon numerous factors such as strength of bite force, material used in the bar, whether the patient is a bruxer, etc. (see Dr. Steven E. Eckert's excellent discussion on this topic at researchgate.net).

For more enlightenment about framework design, the required approach involves stress analysis and the consideration of possible mechanical failure (in order to avoid it).

Consider three example cases, each of which is formulated in 3D finite element (FE) models. Case 1 involves four upright implants (each 4 mm in diameter); Case 2 involves four All-on-4° implants (each 4 mm in diameter, with the distal two implants tilted); and Case 3 involves three Trefoil implants (each 5 mm in diameter). As can be seen in the top row of Figure 2B, the implants support a metal framework that's 5.5 mm wide (bucco-

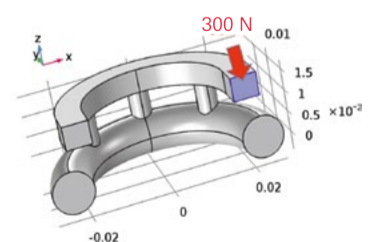

Figure 2A: Illustration of the setup in the 3D finite element modeling of a bar supported by three Trefoil implants. Similar setups were used for the four upright implants and All-on-4° treatment concept implants.

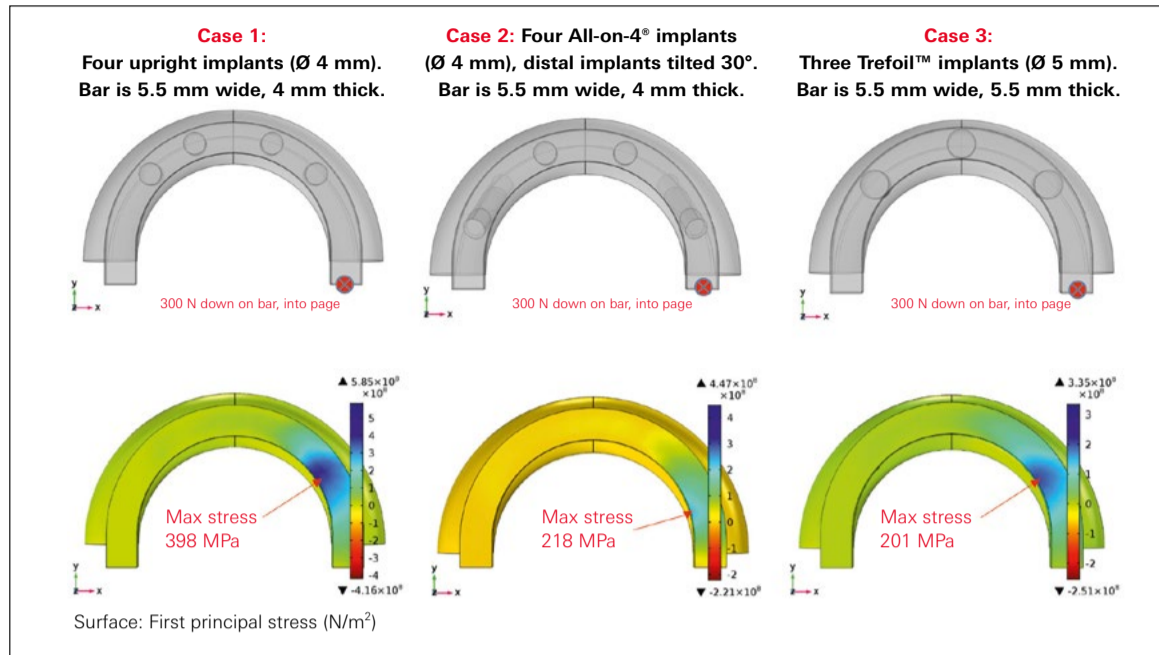
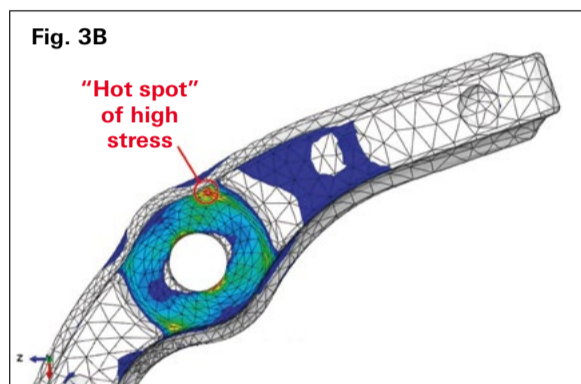
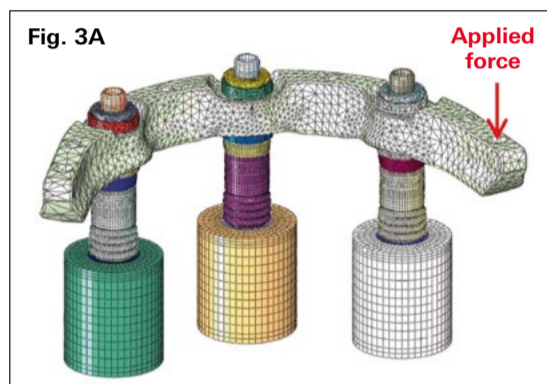

Figure 2B: Overhead views of the bar and implant arrangements (top row) and distributions of tensile stress in the bars for 300 N acting at the right cantilever (bottom row).



Figures 3A and 3B. During the design stage of Trefoil, Nobel Biocare’s stress analysis of the detailed geometry of Trefoil’s bar went beyond the author’s FE examples depicted in Figure 2B. Nobel Biocare’s more detailed analysis of the bar (using its actual geometry instead of the simple U-shape depicted in Figures 2A and 2B) showed that under large cantilever loading, “hot spots” of high stress developed at the base of the cantilever (Figure 3B). Such agreement between FE predictions and experimental test data gives validity to the FE analysis, and confidence in the safety and efficacy of the final bar.

lingually) in each case; but 4 mm thick for Cases 1 and 2 vs. 5.5 mm thick for Case 3. Each bar is loaded downward at the right distal end of the cantilever with a force of 300 N. Each case is formulated and analyzed using 3D FEA.

These models, like all other idealizations, are subject to the usual list of limitations, of course, such as the fact that the models here neglect the fine geometric details of the wide variety of bars, implants, and bone encountered clinically; but they do provide the analytical advantage of uniformity.

Here all three models have the same setup of materials—apart from implant diameter, location and bar size—so it is a straightforward process to make meaningful comparisons between these three crucial variables. The Young’s elastic modulus of the Ti alloy bars is 115 GPa, the modulus of the commercially pure (CP) Ti implants is 105 GPa, and the modulus of the mandibular bone is that of dense cortical bone ≈20 GPa. As seen in Figures 2A and B, the chosen load at the cantilever is 300 N.

Now we’re ready to answer the question, “What stresses develop in the three bars, and how do those stresses relate to possible failure?”

“No design is possible until the materials with which you design are completely understood.”
— Mies van der Rohe

The results (Figure 2B, bottom row) reveal that the maximum tensile stress (1st principal stress) on the top surface of each bar concentrates at the location expected—near the fixed end of the cantilever region. Case 1 (upright 4) shows the largest stress (398 MPa); Case 2 (All-on-4®) has a lower stress (218 MPa); and Case 3 (Trefoil) has the lowest stress of all (201 MPa).

What this means in terms of a likelihood of bar fracture is as follows: If the bars happened to be made of CP Ti, the ultimate tensile strength of some grades of CP Ti is over 700 MPa, so none of the bars made from such a material would be in danger of fracturing. However, since the fatigue endurance limit of some grades of CP Ti is only 300 MPa—which is less than the stress seen in the Case 1 bar (398 MPa)—a CP Ti bar in Case 1 would be at risk of failing by metallurgical fatigue.

On the other hand, the fatigue endurance limit of specially cold-worked Grade 4 CP Ti is ≈430 MPa;

and the comparable value for the Ti-6Al-4V alloy used in the Trefoil Bar is ≈620 MPa—both of which provide ample margins above maximum stress. Bars made of these materials, used in cases like these, would not be expected to fail in fatigue.

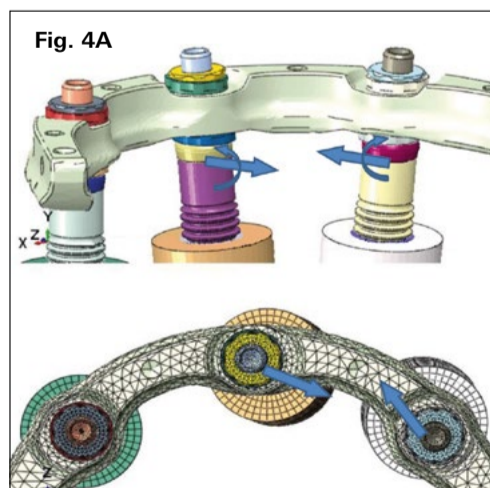

Figures 4A and 4B. Trefoil’s exemplary design became clearly evident when tests were run on bars that fit perfectly on aligned implants (i.e., on implants placed according to the ideal surgical plan, left column above) and bars in which the compensation mechanism became “active” in accommodating a passive fit of the bar to misaligned Trefoil implants (i.e., a situation where two of the implants were purposely misaligned by known angular and lateral shifts, a.k.a. the “Trefoil Worst Case,” depicted in the column to the right).

“Less is more.”
— Mies van der Rohe

Pillar 3: Enlightenment

Thanks to proper design, the Trefoil framework works nicely.

During the design stage of Trefoil, Nobel Biocare’s stress analysis of the detailed geometry of Trefoil’s bar (see Figure 3A) went beyond my FEA examples above; Nobel’s more detailed analysis of the bar (using its actual geometry instead of the simple U-shape assumed for FEA) showed that under large cantilever loading, “hot spots” of high stress developed at the base of the cantilever (Figure 3B). Notably, those hot spots of stress matched well with the locations of fatigue fractures seen in laboratory fatigue testing of bars in saline solution. Such agreement between FEA predictions and experimental test data gives validity to the FEA and confidence in the safety and efficacy of the final bar.

The thoroughness of Trefoil’s design emerges more fully when considering Nobel Biocare’s fatigue comparative testing on bars supported by aligned vs. misaligned implants (Figure 4A). That is, tests were run on bars that fit perfectly on aligned implants (i.e., on implants placed according to the ideal surgical plan) and bars in which the compensation mechanism became “active” in accommodating a passive fit of the bar to misaligned Trefoil implants (i.e., a situation where two of the implants were purposely misaligned to their maximum angular and lateral shifts).

A typical fatigue test was conducted by applying a known cyclic force—say 300 N—at 1 cycle/sec to the end of the cantilever, and then allowing the test to keep running until either “runout” occurred (no bar failure at 2 million cycles) or fatigue failure occurred (e.g., cracks formed) at a specific number of cycles.

The fatigue tests revealed no difference in fatigue performance be-

tween the ideal and worst cases (Figure 4B); the mean fatigue limit (here quoted in terms of force, since these were tests on whole bars) was statistically the same for both cases, at about 313 N.

What these data show is that the compensation mechanism supports reliable and predictable resistance to mechanical fatigue within its full compensation range.

While fatigue tests are usually designed to compare different systems with each other, to gain insight into the role of various material characteristics on fatigue life, it is enlightening nevertheless to consider how we can estimate a practical *in vivo* lifetime of a Trefoil Bar.

For instance, since it’s known from the tests that the bar can withstand at least 300 N of cyclic bite force at the cantilever without failing after 2 million cycles (the point at which the testing was stopped for practical reasons), how long—in days or years—does this mean that the bar will last? An approximate answer can be based on estimates in the literature of a typical chewing rate in humans—60 to 80 cycles per minute—and a typical length of time spent chewing each day—about 9 to 17 minutes per day.

Assuming 60 chewing cycles/min during 10 minutes/day of chewing, this produces 600 chewing cycles per day. We know from fatigue tests that the Trefoil Bar can withstand at least two million cycles with 300 N on the cantilever. So this translates into a *minimum* survival time for the Trefoil Bar of at least 9 years—and it could very well last much longer.

There has really been nothing like this to emerge from the lab to the clinic before! <

→ More to explore!

For the complete list of references for this article, please visit: nobelbiocare.com/news

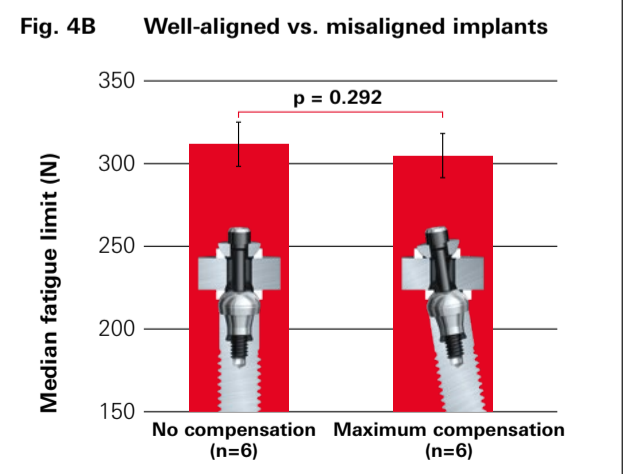

Putting TiUnite® To the Ultimate Test

An interview with Professor Tomas Albrektsson

Involved as he has been with dental implantology from the very beginning, Professor Tomas Albrektsson was a keen observer when Nobel Biocare launched its moderately rough TiUnite surface in 2000.



Professor Tomas Albrektsson began work as part of Per-Ingvar Brånemark's research team in Gothenburg, Sweden, in 1967. In the years that followed, he earned his PhD in anatomy and a Swedish professorship in the subject of handicap research. One of the most quoted scientists in his chosen field, Albrektsson lectures around the world and often moderates symposia and conferences on osseointegration-based treatment and research.

Today, 17 years after the advent of TiUnite, Albrektsson is the co-author—together with Professor Matthias Karl—of a landmark meta-analysis* screening all the prospective studies since published on this remarkable surface. The study has been called the most extensive analysis ever of a single dental brand. It comprises 106 papers in total, featuring well over 12,000 TiUnite implants. In the following interview, Albrektsson explains the significance of the findings.

What is the relevance of looking at research on the TiUnite surface in such detail?

Professor Albrektsson: It is always relevant to have proper clinical studies conducted. But it is the sheer wealth of evidence on TiUnite implants that made this meta-analysis possible. Nobel Biocare is definitely leading the way here. There are some other systematic reviews on a single implant surface or brand, but not many. And the more we know, of course, the better it is for dental professionals and for patients.

Research of this nature highlights the stark contrast between high-quality implants and the copycat versions that are likely not backed by documentation. Even if they seemingly look like the implant that they're trying to imitate, this does not mean they will work in the same way. So this is really the most important thing—that a dental implant really works as planned and that there is high-quality evidence to prove it.

What were the key findings of this TiUnite meta-analysis and why are they important?

Albrektsson: It was reported, not to any great surprise, that there is a very high implant survival rate for implants with the TiUnite surface. We know today that TiUnite has a very good clinical record with maintained bone levels in the vast majori-

ty of cases. There are actually five different ten-year studies on TiUnite that demonstrate well-maintained bone levels.

What does your study tell us about rates of peri-implantitis with TiUnite implants?

Albrektsson: The publications assessing biological complications revealed a low prevalence of peri-implantitis with TiUnite implants. This is also no big surprise. The figures we've seen widely reported in the literature are exaggerated. They say that any bone loss after the first year is caused by disease, which is—to put it mildly—incorrect.

We see maintained bone levels in this study and in other ten-year follow-up studies with TiUnite. If peri-implantitis is a disease—which is being widely discussed at the moment—it may affect one percent of implants at ten years. So, if by 'disease' we mean bone loss that threatens the survival of the implant, it's on the order of one percent.

Nobel Biocare's implant systems are not the only ones showing good results with respect to peri-implantitis, but if I were to choose an implant today, I would look at the documented research, which is so much better with Nobel Biocare. The TiUnite implant surface is backed by more five-

and ten-year studies than implant surfaces from the majority of its competitors. When it comes to supporting evidence, Nobel Biocare implants have the advantage.

How can the findings of this meta-analysis be used to optimize clinical practice?

Albrektsson: I think that we have to strive for continuous improvement. In the 1800s, if you had 19% mortality in appendicitis cases, you were better than the average doctor. Today such a mortality rate would see you lose your license because we have new techniques. It's a similar story with dental implants—we have to constantly challenge what we currently consider to be the ultimate implant solution in order to have even better solutions for patients in future.

It is a continuing mission, and I know that Nobel Biocare is involved in a number of studies with a view to making further improvements. I think this is exactly the right approach because in the ideal situation we'll have a 100% survival and success rate at ten years. We aren't there yet, but that's the goal.

You have been involved with research evaluating Nobel Biocare implants for many years. Have the findings of your analysis changed your perception of the TiUnite surface in any way?

Albrektsson: The meta-analysis is another validation of TiUnite's efficacy, but other types of clinical studies have previously confirmed its high performance. Meta-analysis offers high-quality insight, but you need a wide range of supporting evidence, and TiUnite is backed not just by prospective studies, as we examined, but by retrospective research and other study types as well. The statements we make about TiUnite implants today can therefore be made with great confidence.

I observed TiUnite being launched in the year 2000. I believed in it then and now I know that my beliefs were correct. It is a superb implant surface. <

→ More to explore!

For more information about the TiUnite surface and its supporting clinical evidence, visit nobelbiocare.com/tiunite.



Setting the scientific standard. Again.

The evidence points to TiUnite®

The largest ever meta-analysis of a single implant brand unequivocally confirms the clinical success of the TiUnite surface.

A serious implant surface backed by serious scientific data

TiUnite supports peri-implant health, bone maintenance and overall success.

95.1%

10-year implant survival at implant level

1.36%

Peri-implantitis Lowest estimate

-0.9 mm

Bone level change at 5-year follow-up

(Authors postulated that peri-implantitis did not occur in studies where it was not explicitly reported.)

Insurmountable TiUnite

Unequivocally confirmed by the largest ever meta-analysis assessing a single implant brand.

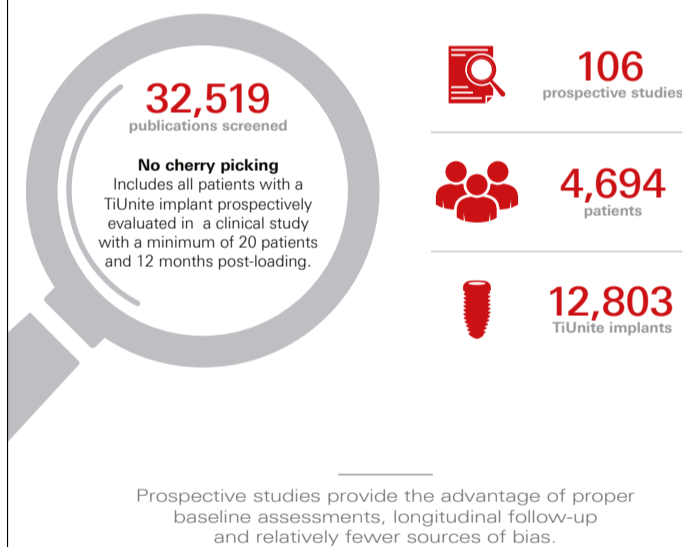

The highest-level evidence

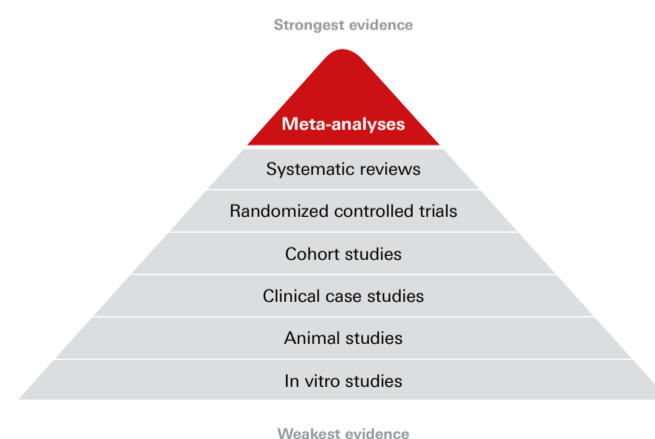

* **Matthias Karl and Tomas Albrektsson** have co-authored the "Clinical performance of dental implants with a moderately rough (TiUnite) surface: A meta-analysis of prospective clinical studies," Int J Oral Maxillofac Implants. 2017 Jul/Aug;32(4):717-734. doi: 10.11607/jomi.5699.

Building on a Strong Foundation Together with Nobel Biocare

An ingenious, elegant model for success

A team of three American periodontists has developed and refined a practical method for professional success that has made it possible for their referral-based practice to consistently increase revenue—at a remarkable rate of 10 percent per year—for decades. Drs. Crosby, Kolinski and Trahan have been able to do this despite an evolving market that is challenged by increasing numbers of dentists placing implants, a national trend toward corporate-based dentistry, and attrition of the referral base due to the retirement of referring doctors.

By Richard M. Sullivan, DDS

When he started his periodontal practice in 1980, Dr. Martin Kolinski had the insight and good judgement to establish three important ground rules. First, he would build strong interdisciplinary relationships with well-educated, referring restorative dentists. Second, he would commit his practice to unparalleled customer service for his patients and their referring doctors (which, as it would turn out, would ensure a flow of new and continuing patients for the lifetime of his expanding specialty practice). Third, as implants were to become a significant part of his new practice, he would choose to work with a company that had a well-established reputation for excellence.

He needed to find a company that could become an integral part of the practice's reputation and professional development. Nobel Biocare proved to be the perfect match. Looking back, it now seems all but inevitable that the practice Kolinski founded would become a Diamond partner with the company, a status he and his colleagues have maintained for over 25 years.

From the outset, Kolinski began providing continuing education programs for his referring doctors while, at the same time, serving as a clinical professor at the University of Illinois School of Dentistry. It was there that he met his future practice partner, Dr. Tricia Crosby, who began as an associate in 2007 and established partnership in the practice in 2010. Together, they formed a

strong clinical team that greatly increased the scope and size of their practice and enabled the delivery of continuing education programs that far exceeded what either could have achieved individually.

Continuing education is key

Through diligent documentation of his cases, Dr. Kolinski had developed years of clinical material that he prepared and presented for programs and seminars held by the Chicago Dental Society, the American Academy of Periodontology and the Academy of General Dentistry.

According to Kolinski, "Dr. Crosby brought not only outstanding treatment planning and surgical abilities to our practice, she also brought finely-honed lecturing and demonstration skills that were immediately used to refine and improve our presentations."

The long-term successes and versatility of Nobel Biocare implant systems significantly contributed to the materials that Drs. Kolinski and Crosby were able to develop. Within three years of joining the practice, Crosby had contributed an impressive repertoire of cases to their joint educational effort and achieved professional recognition of her own as a certifying examiner for the American Board of Periodontology.

From the beginning of their collaboration, these two periodontists have committed themselves to developing new topics each year for the continuing education programs they organize.

"We do our best to create presentations with timely relevance in the areas of implantology and periodontics," explains Dr. Crosby. These presentations are based solely on their own clinical cases and related experiences. "We typically present our programs to over one hundred doctors and dental hygienists each year, and our seminars serve as a basis for enduring collaborative relationships that provide stability and growth for our practice."

Dr. Kolinski adds, "In order to ensure optimum results, we always emphasize the importance of using original Nobel Biocare components. Many of the problems with screw loosening, for example, can be attributed to using substandard parts."

Always interested in staying at the cutting edge of his profession, Dr. Kolinski was one of the original investigators for the NobelActive implant. He was also the lead author for



Periodontists, Drs. Martin Kolinski and Tricia Crosby have followed three basic ground rules in order to establish and maintain a highly successful dental implant practice.

the ongoing, prospective NobelActive 3.0 study, recent results of which were just published.

Opening doors for referring dentists to provide new or improved collaborative procedures has resulted in beneficial growth for the referring dentists as well as for the periodontists' office, which allowed them to bring a new associate, Dr. William Trahan, into the practice over two years ago.

"Our practice now has three doctors," says Dr. Kolinski, "each of whom are working hard to document cases in order to contribute to the literature and the profession."

The two senior partners also serve as adjunct faculty at the University of Illinois at Chicago's College of Dentistry.

Essential collaboration

Over the lifetime of the practice, Drs. Crosby, Kolinski and Trahan have placed over 20,000 Nobel Biocare implants, which renders them among the most experienced of implant surgeons and provides excellent experience and credentials for their teaching endeavors.

For the foreseeable future, these three will continue to collaborate with the lifeblood of their practice, the referring doctors. Facing mounting pressure by insurance companies and corporate institutions to drive

down the cost and, in some cases, the resulting quality of implant therapy, the practice will continue to place emphasis on the expertise and quality that they will always make available to a patient base that demands optimum treatment.

Back in 1980, Dr. Kolinski was just a young visionary who was determined to build a successful practice based on three simple premises. Well-established today, he and his colleagues enjoy the fruits of developing professional relationships that continue to ensure quality care, delivered through interdisciplinary rigor, and supported by well-conceived continuing education.

Their emphasis on state-of-the-art, quality treatment, combined with impeccable customer care has paid high dividends and created a template for longevity that grooms each doctor from associate to partner, fostering mutual achievement. Together, Crosby, Kolinski and Trahan have developed a solid, well-proven, specialty practice model that bodes well for the future of their enterprise. <

→ More to explore!

Find out how Nobel Biocare can help you grow your practice, please visit the Practice Resource Center at: nobelbiocare.com

Upcoming Events

Meet Nobel Biocare at events around the world. These professional gatherings provide a great opportunity for catching up with the latest innovations and scientific research.

• 2018 •

Centennial Meeting of the Academy of Prosthodontics
May 9-12
Chicago, IL, USA

SEPES Primavera
May 19
Madrid, Spain

EAED European Academy of Esthetic Dentistry, 32nd Spring Meeting
May 24-27
Sorrento, Italy

EuroPerio9
June 20-23
Amsterdam, Netherlands

FDI World Dental Congress
September 5-8
Buenos Aires, Argentina

EAO European Association of Osseointegration
October 11-13
Vienna, Austria

American Academy of Periodontology 104th Annual Meeting
October 27-30
Vancouver, Canada

American College of Prosthodontists 48th Annual Session
October 31-November 3
Baltimore, MD, USA

Swedental Annual Dental Congress
November 15-17
Gothenburg, Sweden

Greater New York Dental Meeting
November 25-28
New York, NY, USA

ADF Association Dentaire Française Annual Meeting
November 27-December 1
Paris, France

AAOMS Dental Implant Conference
November 29-December 1
Chicago, IL, USA

DGI 32nd Congress
November 29-December 1
Wiesbaden, Germany

• 2019 •

Nobel Biocare Global Symposium
June 27-29
Las Vegas, NV, USA

→ More to explore!
For the most recent updates, visit: nobelbiocare.com/events

Brånemark Osseointegration Award

The man behind the breakthrough Trefoil system receives recognition from colleagues for a lifetime of good work.

Dr. Kenji W. Higuchi, an American oral and maxillo-facial surgeon, and the man who first devised and gave impetus to the development of the Trefoil system for full-arch mandible rehabilitation, recently became the 11th recipient of the Nobel Biocare Brånemark Osseointegration Award.

The Nobel Biocare Brånemark Osseointegration Award is presented each year by the Osseointegration Foundation (OF), the Academy of Osseointegration's (AO) philanthropic arm. It honors an individual whose impact on implant dentistry is exemplary in any or all of the Foundation's mission categories: research, education and charitable causes. Dr. Higuchi has been a force to reckon with in all three areas.

As a thought leader and innovator, taught and inspired by Professor Per-Ingvar Brånemark, Dr. Higuchi has always focused on the patient first. Still active today, he continues to be instrumental in the development of revolutionary forms of treatment that make implant solutions accessible to an ever growing number of patients.

On hearing of the award, Dr. Higuchi said, "I am deeply honored. This is especially gratifying because of my close and long-term relation-

ship with Professor Brånemark."

Dr. Higuchi played a key role in the original development of Brånemark's Novum concept, making him the ideal candidate to pick up the torch from the well-known Swedish professor, in order to bring its new incarnation, Trefoil, to doctors and patients around the world today.

Well-deserved recognition

Known not only for his research, but also as an educator of rank and an elder statesman in the profession, he was clearly pleased for the implicit acknowledgement of a job well done.

"It is personally meaningful to be recognized by the Osseointegration Foundation for past involvement in research, education, and humanitarian service," he said, "as all these activities have been of central importance to me."

The President of the Osseointegration Foundation, Dr. Edward Sevetz, presented the award to Dr. Higuchi during the Opening Symposium of the Academy's 2018 Annual Meeting in Los Angeles, California.

Introducing the laureate, he said, "Dr. Kenji Higuchi's professional and personal experiences and characteristics qualify him for being a role model for anyone in the dental healthcare field. Almost 40 years ago, he developed a close working relationship with the discoverer of osseointegration.

"Dr. Higuchi worked side-by-side with Professor Brånemark," Sevetz continued, "and became one of the earliest surgeons in the U.S. to recognize the breakthrough of osseointegration, and how it would vastly improve the quality of the lives of patients."

The OF President considers the award winner to be a humanitarian as well as an innovator: "Dr. Higuchi annually took time out of his own private practice to coordinate professional training sessions to 'raise the bar' of those wishing to help patients in their own locales."

Dr. Higuchi is a diplomate of the American Board of Oral and Maxillofacial Surgery. His private practice (Drs. Higuchi and Skinner PS) emphasized reconstructive oral and maxillofacial surgery. Since 1984, he has been the director of The Spokane Center for Tissue Integrated Reconstruction, and since 2007, Dr. Higuchi and Professor John Brunski, Stanford University, have been the principals in OsseoConception LLC.

From 1986 to 2018, Dr. Higuchi participated in ten separate multi-center prospective clinical trials, most recently relating to his brainchild, the Trefoil system. <

→ More to explore!

For more information about the revolutionary Trefoil full-arch solution: nobelbiocare.com/trefoil.



"With his humanitarian heart, science-oriented mind and openly friendly personality, Dr. Higuchi (pictured above) is an exemplary role model to all of us on how to lead our professional and personal lives," says the President of the Osseointegration Foundation, Dr. Edward Sevetz.



Nobel Biocare NEWS

Printed on non-chlorine bleached FSC-certified paper.

Read us online at:
nobelbiocare.com/news

Headquarters

Nobel Biocare Services AG
P.O. Box
8058 Zürich-Flughafen, Switzerland

Offices:
Balsberg, Balz-Zimmermann-Strasse 7
8302 Kloten, Switzerland
Phone +41 43 211 42 00
Fax +41 43 211 42 42



Web contact: nobelbiocare.com/contact

Americas

Brazil
Nobel Biocare Brazil
Phone: 0800 16 999 6

Canada
Nobel Biocare Canada
Phone: +1 800 939 9394

Chile
Dental Biocare
Phone: +56 220 19282

Colombia
Hospimedics S.A.
Phone: +57 1 640 0608

Mexico
Nobel Biocare Mexico
Phone: +52 55 524 974 60

USA
Nobel Biocare USA
Phone: +1 800 322 5001

Asia Pacific

Australia
Nobel Biocare Australia
Phone: 1800 804 597

China
Nobel Biocare China
Phone: +86 400 081 7707

Hong Kong
Nobel Biocare Hong Kong
Phone: +852 2845 1266

India
Nobel Biocare India
Phone: 1800 266 9998

Japan
Nobel Biocare Japan
Phone: +81 3 6408 4182

New Zealand
Nobel Biocare New Zealand
Phone: 0800 441 657

Taiwan
Nobel Biocare Taiwan
Phone: +886 080 00 779

Europe, Middle East and Africa

Austria
Nobel Biocare Austria
Phone: +43 1 892 89 90

Belgium
Nobel Biocare Belgium
Phone: +32 2 467 41 70

Denmark
Nobel Biocare Denmark
Phone: +45 39 40 48 46

Finland
Nobel Biocare Finland
Phone: +358 20 740 61 00

France
Nobel Biocare France
Phone: +33 1 49 20 00 30

Germany
Nobel Biocare Germany
Phone: +49 221 500 850

Hungary
Nobel Biocare Hungary
Phone: +36 1 279 33 79

Ireland
Nobel Biocare Ireland
Phone: +44 208 756 3300

Israel
Nobel Biocare Israel
Phone: +972 3 9291000

Italy
Nobel Biocare Italy
Phone: +39 800 53 93 28

Lithuania
Nobel Biocare Lithuania
Phone: +370 5 268 3448

Netherlands
Nobel Biocare Netherlands
Phone: +31 30 635 49 49

Norway
Nobel Biocare Norway
Phone: +47 64 95 75 55

Poland
Nobel Biocare Poland
Phone: +48 22 395 73 60

Portugal
Nobel Biocare Portugal
Phone: +351 800 300 100

Russia
Nobel Biocare Russia
Phone: +7 495 974 77 55

South Africa
Nobel Biocare South Africa
Phone: +27 11 802 0112

Spain
Nobel Biocare Spain
Phone: +34 900 850 008

Sweden
Nobel Biocare Sweden
Phone: +46 31 335 49 00

Switzerland
Nobel Biocare Switzerland
Phone: 0800 211 424

United Kingdom
Nobel Biocare UK
Phone: +44 208 756 3300

Distributor Markets

Algeria, Bulgaria, Croatia, Cyprus, Czech Republic, Greece, Jordan, Kuwait, Lebanon, Malta, Macedonia, Qatar, Romania, Saudi Arabia, Serbia and Montenegro, Slovenia, Slovakia, Tunisia, Turkey, United Arab Emirates
Phone: +34 933 560 562

Southeast Asia Distributor Markets:

Indonesia, Malaysia, Singapore, South Korea, Thailand, Vietnam
Phone: +852 28238925

South Asia Distributor Markets:

Bangladesh, Nepal, Pakistan and Sri Lanka
Phone: +91 22 67519999